

FilterBox 10M

50 Hz

A cost efficient manually cleaned unit for light to medium dust and fume applications.

The FilterBox 10M is a mobile unit equipped with a N24 fan for a maximum air flow capacity of 1 000 m³/h (600 CFM). An integrated silencer reduces noise from the fan and outlet air.

The filter cartridge is manually cleaned. Depending on the model, it is equipped with mechanical cleaning for dust applications or a combination of mechanical and compressed air cleaning for fumes.

Additional protection from harmful particles is provided if a HEPA H13 filter is installed.

Standard features

- 3 m (10 ft.) Nederman Original extraction arm
- Dust free emptying of dust bin
- Ergonomic change of filter cartridge
- Polyester filter cartridges with 99% separation efficiency
- Silencer
- Filter indicator with alarm
- Operating hours meter
- Automatic damper minimizing dust leakage during pneumatic cleaning
- Easily maneuverable extractor arm
- 9.5 m (31 ft.) power cable
- Third party approval for welding fumes, category W3 EN 15012



Dimensions

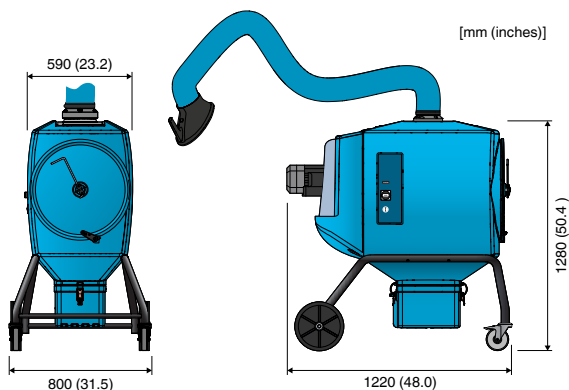

Technical Data

Air flow	Up to 1000 m ³ /h (600 CFM)
Fan	N24, 0.9 kW/1.2 hp (0.75 kW/1 hp single phase)
Filter cartridge	13 m ² PW13, polyester
Filtration efficiency	99 %*
W3 approval	Yes
Weight	102 kg (225 lbs)
Noise level	66 dB(A)
Extraction hose diam.	160 mm (6 ¼ in)

* average weight filtration efficiency

Models

Assembly	Filter cleaning system	Fan motor power	Voltage (V)	Frequency (Hz)	Phases	Filter cleaning method	
						Mechanical	Mechanical + pneumatic
Mobile	Manual	0.9 kW (1.2 hp)	230	50	3	12651863	12652263
Mobile	Manual	0.9 kW (1.2 hp)	400	50	3	12651963	12652363
Mobile	Manual	0.75 kW (1.0 hp)	230	50	1	12652063	12652463
Mobile	Manual	0.75 kW (1.0 hp)	110	50	1	12652163	12652563

Accessories

Accessory	Description	Article number
HEPA filter	Filtration efficiency 99.95 % (H13)	12376615
Spotlight on hood (Original)	Placed on hood	10551235
Ergonomic handle	For improved mobility	12376617
Spark protection (Original)	Mounted on hood	10551335
Plastic bag	Bags for dust bin	12376618

Replacement filters

Replacement filters	Used for	Filtration efficiency (%)	Filter surface, m ² (ft ²)	Article number
HEPA filter	Higher filtration efficiency	99.95 % (H13)	10 (108)	12376615
Standard filter cartridge PW13	Welding, dust	99	13 (140)	12332672
High efficiency filter cartridge PWHE15	Dust, stainless steel welding	99.9	15 (162)	12371106
Antistatic high efficiency filter cartridge PWAHE15	Dust	99.9	15 (162)	12371412